

Installation Instructions

Surface Fixed

Harmony Flowers
Page 1 of 2



Instrument Components:

Metric Conversion:
1100mm/”
1.5m/ 59”

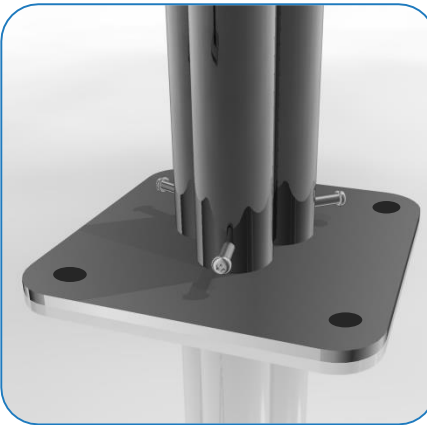
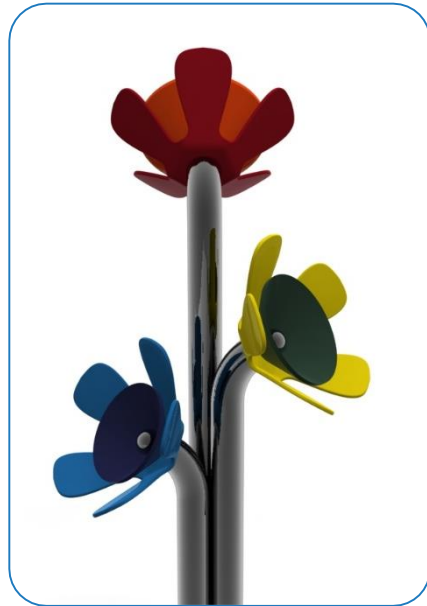

Weight of heaviest part 6kg (Surface Plate)

1. Unpack ground fixing legs 3no.

2. Lay packaging out on floor or assemble on non-abrasive surface to prevent marking of polished stainless steel.

3. Align holes on legs to holes on surface fixing (opposite end to polished domes) and secure in place using 3no. M10 x 30mm Screws provided. Tools required TX 45 Driver Bit)

4. Invert assembled frame so flowers are at the top.

5. **Locate Flowers** in desired location and mark holes to fix to desired surface.

6. Fix to Surface using recommended ground anchors (**Ground Anchors are not supplied**)

7. Make sure all fixings are covered and secure using cover caps provided

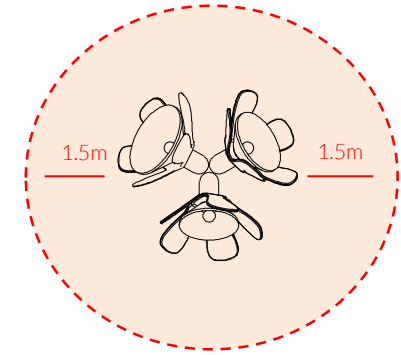

Install Instrument with 1.5m free space (from widest point) around it.

1100mm from Plate

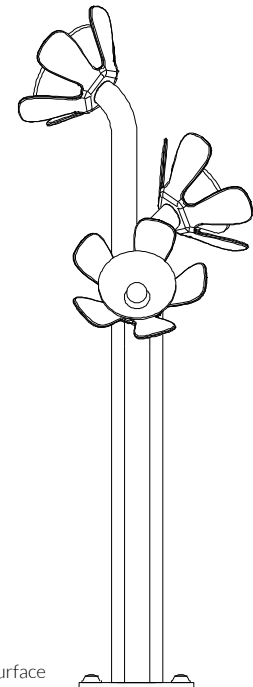

Ground Surface



Small Beaters X3

Surface Fix Components:



M10x30 Security Screw x3



2 Part Cover Cap x4

Ground Anchors not supplied

Spares available from percussionplay.com or from your local distributor

21 Kg

Tools:

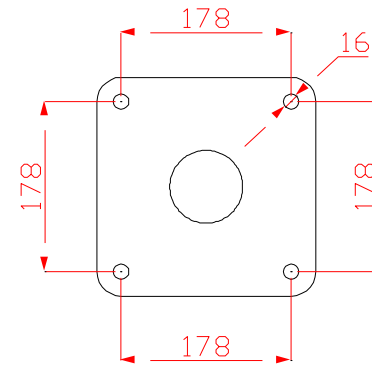

Surface Fixed

Harmony Flowers
Page 2 of 2



Instrument
Components:

Thread Lock Solution
Required

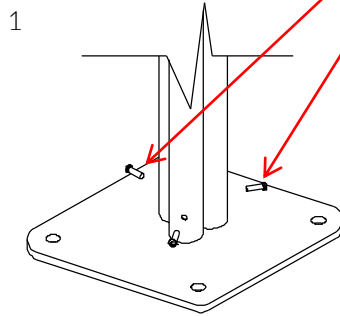

1
Locate the Surface fix Plate into the leg of the instrument.

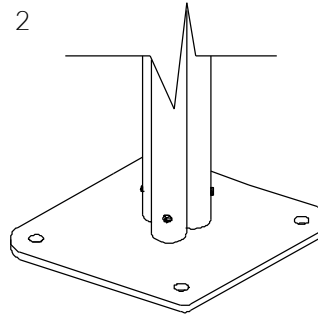

2
Fix instrument to Surface fix plate using M10 Screws and use **thread locking solution** to prevent fixings working loose.

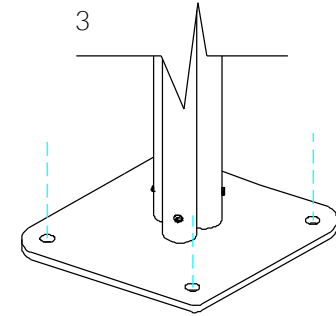

3
Fix Surface Plate to the ground surface **Ground Anchors Not provided** cover fixings with caps provided

Thread Lock Solution
Required



Small
Beaters X3

Surface Fix
Components:



Ground Anchors
not supplied

Spares available from
percussionplay.com or from your
local distributor

21 Kg